

These instructions and the equipment described are in accordance with **BS EN 1298** and in compliance with **BS EN 1004:2004**

**MAXIMUM SAFE WORKING LOAD: 200kg**

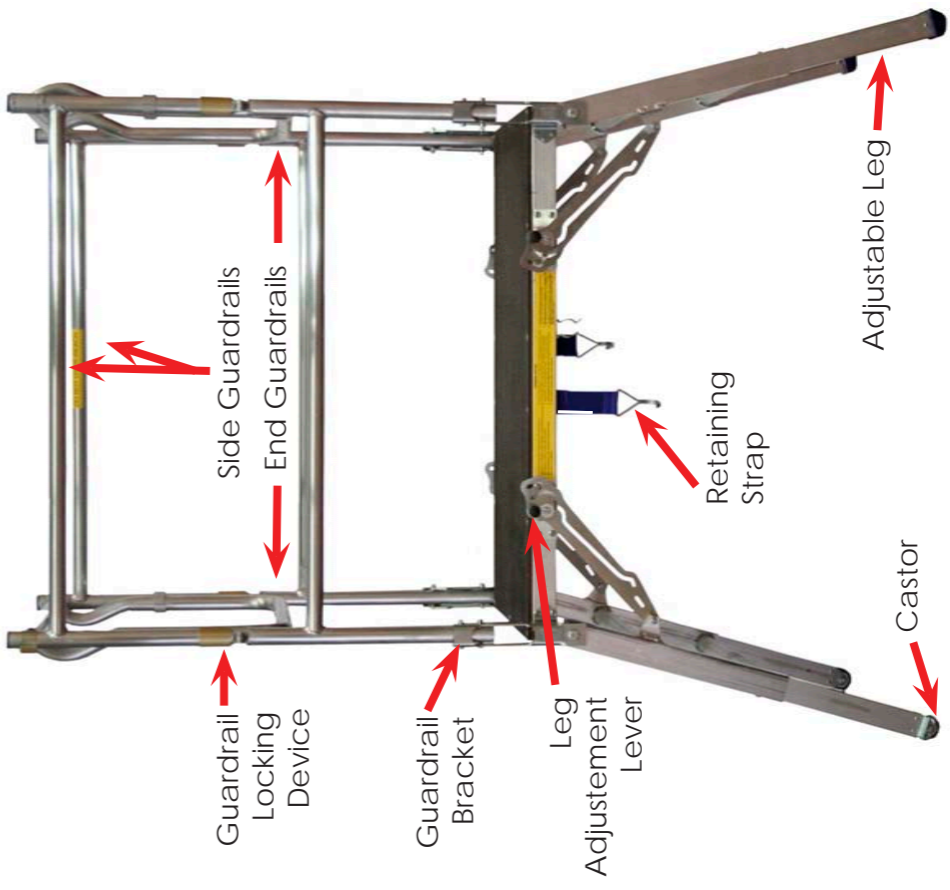

# DELTADECK ASSEMBLY GUIDE

## PLATFORM HEIGHT

Platform height can be adjusted by two methods:

### LEG ADJUSTMENT LEVER

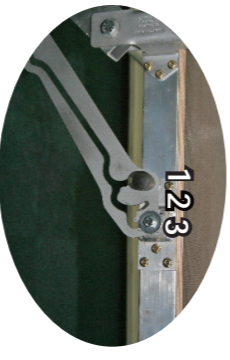

There are 3 positions in which the lever can be placed.

Each position has the effect of adjusting the height of the platform and either increasing or decreasing the footprint of the unit.



Release leg adjustment lever and pull platform toward you until lever engages in either position 1, 2 or 3.

### ADJUSTABLE LEG

The platform height is also adjustable by extending the telescopic leg (3 positions).

To extend the leg, depress the leg retaining device and extend leg to the next position (leg retaining device will automatically relocate).



Leg Retaining Device

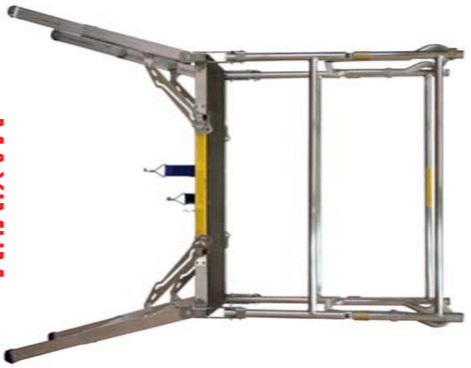

MAXIMUM  
PLATFORM HEIGHT

## DELTADECK DISMANTLE

- Open both end guardrails and rotate top half of side guardrail through 180 degrees (reversal of assembly procedure) by lifting the locking sleeves (See **note** if using Mark One) ensuring that the guardrail chosen has roll pin located in the lowest slot of guardrail bracket (this enables unit to be folded in correct sequence).
- Disengage base of guardrail and lay guardrail unit onto platform.
- Repeat for other side guardrail.

**NOTE - MARK ONE**

Depress locking mechanisms on knuckle joints.



## GENERAL SAFETY & MAINTENANCE NOTES

- Check all components are available and operational
- Inspect the unit components for signs of damage or incorrect function prior to use. Damaged or incorrect components (or components showing signs of excessive wear) must not be used and should be returned to your local supplier. Castors should be periodically lubricated to keep them free running.
- Unit is designed for internal use only on flat, level surfaces. Check that the ground is capable of supporting the weight of the Deltadeck and equipment.
- The safe working load of the Deltadeck platform is **200 kg uniformly distributed; 200kg total load per unit**. One person **only** working on unit at any one time.
- Castors must be locked when unit is in use.
- Ensure that the platform is free of persons and equipment, and that brake locks are off prior to movement. Beware of soft or uneven ground and overhead obstructions.
- Mobile access unit must only be moved by pushing at the base.
- Always beware of live electrical apparatus, cables or moving parts of machinery.
- To prevent accidental injury ensure safe positioning of hands and fingers when assembling and dismantling.
- The Deltadeck should always be climbed with Operator's Centre of Gravity towards the platform.
- Never jump onto platforms. Ensure platform is debris free.
- Do not use hoisting arrangements on Deltadeck unit. When raising or lowering components always work within the unit base.
- Ensure guardrails and gates are locked and secure when platform is in use.
- Deltadeck units are not designed to allow them to be lifted or suspended.
- Never use this equipment, if you are ill, feeling tired, or under the influence of alcohol or drugs.
- Wear practical, protective clothing, gloves and footwear.
- Avoid loose garments and jewellery that could catch in moving parts and tie back long hair.
- Ensure the work area is well lit and ventilated, if in doubt, ask about lighting and ventilation equipment from your local supplier. *Do not work near flammable gases or liquids, petrol or paint thinner turns for example. Keep combustible materials at a safe distance - at least 5m.*
- Make sure that anyone in the immediate work area is warned of what you are doing.
- Keep children, animals and bystanders away from the work area. Cordon off a NO GO area using cones and either barriers or tape, available from your local supplier.
- Do not use boxes, ladders or other such means to gain additional height at the platform.
- Care should be taken when using power tools, wash jets or other such tools which can cause a lateral force on the Deltadeck.
- Ensure that telescopic leg is free from contaminants and lubricated at regular intervals.

*This equipment should be used by an able bodied, competent adult who has read and understood these instructions. Anyone with either a temporary or permanent disability, should seek expert advice before using it.*

## INTRODUCTION

## DELTADECK

If further extension is required, then repeat the previous step until final position is reached.



- Attach the retaining straps.
- Retract all adjustable legs to their minimum adjustment by reversing steps taken during assembly procedure.
- Pull leg adjustment levers and locate legs under platform.
- Repeat for opposing end.

## REMEMBER

**DO NOT OVER REACH THE GUARDRAILS. THE DELTADECK IS AN ALTERNATIVE TO STEP LADDERS AND SHOULD BE USED WITH THIS IN MIND**

**CARE SHOULD BE TAKEN WHEN ACCESSING OR EGRESSING THE PLATFORM.**

# DELTADECK ASSEMBLY GUIDE

## DELTADECK ASSEMBLY

It is essential to familiarise yourself with the equipment before commencing assembly procedures. The Platform must be assembled before use.



Mark One

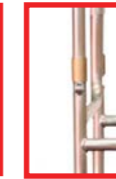

Mark Two

**Note**  
 Mark One - make sure knuckle joint is in locked position  
 Mark Two - make sure sleeve is placed over knuckle joint

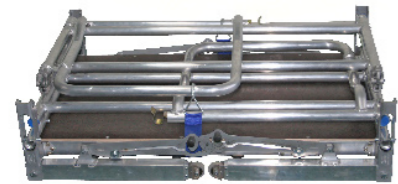

To assemble the platform, take the unit to the work area.

1. Lift one end of platform and simultaneously pull the leg assembly out until legs automatically lock in place.



2. Repeat operation to other side (ensuring locking mechanisms are set at the same height).  
Undo retaining straps.

3. Lift one side guardrail section and rotate top section of guardrail through 180 degrees to allow both sections of guardrail to be locked together (at Guardrail locking device).



4. Repeat for opposing side guardrail.



**Note** Double check that locking positions at base of the guardrail are firmly secured.



5. Place end guardrail as shown.
6. Ensure that castors are locked



UNLOCKED



LOCKED

## DELTADECK

### COMPACT DIMENSIONS

Height	320mm
Length	1110mm
Width	730mm

### PLATFORM HEIGHTS

1	450mm
2	530mm
3	600mm
4	730mm
5	870mm



7. Once castors are locked access can be gained to platform.



**Note** When accessing platform, keep body's centre of gravity towards platform.



8. Once access has been gained, immediately close guardrail behind you to provide protection to all 4 elevations of platform.



## DAILY CHECKS

The unit must be checked on a daily basis and after any event which may have affected the integrity of the unit.

Use the checklist below prior to use.

- Castors Locked
- Adjustable legs and levers located and secure
- Guardrails fitted and secure
- Platform is level and placed on a level and suitable surface

If a box has not been ticked, do not use the unit until the fault is rectified.

Where a fault is found, access to the unit must be stopped.